

Chapter 11

HIGH PERFORMANCE TUNNEL BORING MACHINE FOR QUEENS WATER TUNNEL, NO. 3: A DESIGN AND CASE HISTORY

Brian B. Khalighi and Joseph J. Diehl
Atlas Copco Robbins Inc. and Grow Tunneling Corp.

ABSTRACT

This paper discusses the Queens Water Tunnel, No. 3, Stage 2, being driven by a new Robbins High Performance (HP) Tunnel Boring Machine (TBM). The paper is divided into four sections. In the INTRODUCTION section, a short overview of the scope of the project is presented. In the GEOLOGY section, the geological condition along the tunnel drive is briefly introduced. The TBM DESIGN section discusses the various design criteria and the resulting machine specifications. The paper concludes, in the TBM OPERATION section, with a case history describing the tunneling operation from start-up to the time of the writing of this paper.

INTRODUCTION

Water Tunnel No 3, a project of the New York City Department of Environmental Protection (DEP), will improve fresh water distribution throughout the city. After completion, it will allow for the much needed maintenance of two existing tunnels that have been operating continuously since 1917 and 1936. When finished, the tunnels supply about 90% of the water consumed by the city and its residents, currently at 5.7 million m³ (1.5 billion gal) a day. Water Tunnel No. 3 ranks as the largest and most costly construction project in history of New York City. Total excavation involves 93 km (58 mile) of tunnel with construction divided into four stages. Stage 1, a 21 km (13 mile) long drill and blast tunnel is complete. Stage 2, now underway, is divided into three sections. It comprises a total of 24 km (15 mile) of interconnected tunnels, extending from the end of stage 1 tunnel, to serve the boroughs of Brooklyn, Queens, and Manhattan. Stages 3 and 4 are presently being planned and designed. In March of 1995, the Joint Venture of Grow-Perini-Skanska was low bidder at \$172,467,000 for the construction of Water Tunnel No. 3, Stage 2, underneath the borough of Queens in New York City.

GEOLOGY

The project consists of boring of more than 7.6 km (25,000 ft) of tunnel at 7.06 m (23 ft 2 in) diameter through hard and jointed formations of varying rock types including biotite-hornblende gneiss intermixed with granitic gneiss, amphibolitic, pegmatite, and biotite schist. one section of rhyolitic schist has been confirmed by test to have an unconfined compressive strength of 275 MPa (39,000 psi). Cherchar Abrasivity Index for some typical samples is in the 3.3 to 4.3 range indicating a fairly high abrasivity. After completion boring,

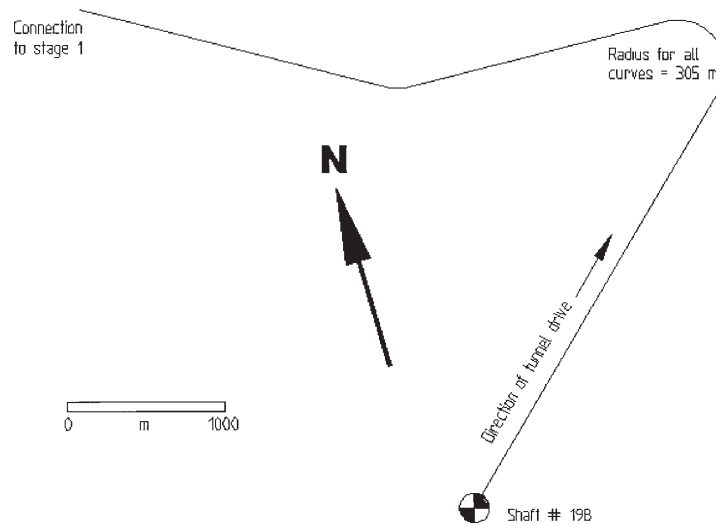

Figure 1. Queens Tunnel Route

the tunnel will be concrete lined to a finished diameter of 6.1 m (20 ft 0 in).

The tunnel begins at shaft 19B, which is 9.1 m (30 ft) diameter and 204 m (670 ft) deep, and advances NE at an average slope down of 4.2%. The shaft forms the only point of access and egress during excavation.

As indicated in Fig. 1, the tunnel negotiates a 116(curve to the left after approximately 3 km (1.9 mile) and then continues in a westerly direction, with two more curves, before it connect to the Stage 1 tunnel.

TBM DESIGN

TBM Selection

Based on the geological conditions expected to exist along the tunnel , it was clear that the machine chosen would be of the High Performance (HP) open hard rock type. These types of machines are well suited for competent ground conditions where support will be occasional and consists mainly of rock bolts, ring beams, or wire mesh. Due to the open design, access to the walls and crown is relatively easy, allowing for the placement of supports as required.

The Robbins HP open hard rock TBM, as shown in Figure 2., weighs 610 metric tons (1,345,000 lb) approximately and has a diameter of 7.06 m (23 ft 0 in). The machine can be modified to any diameter between 6.50 m (21 ft 4 in) and 8.50 m (27 ft 11 in), making it suitable for future hard rock tunneling projects. The TBM consists of three major components, the Cutterhead/Cutterhead support, Gripper, and Main Beam assemblies.

HIGH PERFORMANCE TUNNEL BORING MACHINE FOR WATER TUNNEL 203

The cutterhead support houses the main bearing, main drive gear, seals, and the cutterhead drive train. These consist of an electric motor, gear reducer, and hydraulic clutch. The cutterhead support assembly also includes the front, side, and roof supports. These supports firmly stabilize the cutterhead during boring and ensure precise cutter tracking.

The main beam assembly consists of the main beam and rear section which is connected to the main beam by a bolted flange. The forward end of the main beam assembly is bolted to the cutterhead support. The aft end of the main beam is supported by the gripper assembly during the boring cycle. The gripper assembly consists of the gripper cylinder, gripper carrier, and gripper shoes. This assembly provides reaction to the forward thrust of the machine. The main beam can be moved up, down, or sideways relative to the tunnel axis throughout the full working stroke. This is how the TBM is steered. The function of the rear section is to support the weight of the machine during the regrip cycle, when the gripper carrier is being moved forward to begin the next boring cycle. Additionally, the back-up towing system is connected to the rear section legs.

Table 1. Specifications for 235-282 HP TBM

TBM Diameter.....	7.06 m (23 ft 2 in)
Diameter Range.....	6.50 m (21 ft 4 in) to 8.50 m (27 ft 11 in)
Cutter Size.....	482.6 mm (19 in)
Cutter load capacity.....	311 kN (70,000 lb)
Number of Cutters.....	50
Cutterhead Thrust.....	15,550 kN (3,500,000 lb)
Cutterhead Power.....	10 x 315 = 3150 kW (4220 hp)
Cutterhead Torque.....	3624 kNm (2,669,000 lb-ft)
Cutterhead Speed.....	8.3 rpm

Cutters

The 50 cutters installed on this TBM are of Wedge Lock type and have a disc diameter of 482.6 mm (19 in). Compared to the traditional V Block mounted cutters, the wedge lock cutters are simpler to install, more efficient, less expensive, and require less time for cutter change. The wedge lock not only provides a stable mounting of the cutter shaft with proper line contact on the seat, rather than the point contact seen in the V block mounting, it also takes the load off the mounting bolts. It also takes less time to mount a wedge lock cutter than a V block mounted one as there are less number of parts to handle.

Cutterhead

The cutterhead has a diameter of 7.06 m (23 ft 2 in) with new cutters. The construction of the cutterhead consists of a cylindrical center section and two outer cutterhead segments. 50 front loading cutter housings are strategically located and welded to the face of inner and outer cutterhead segments to provide the optimum cutter spacing. The outer cutterhead segments are bolted onto the inner cutterhead and then field welded at the tunnel site.

Main Bearing and Drive System

The main bearing, as shown in Figure 3, is a three element roller bearing. This is

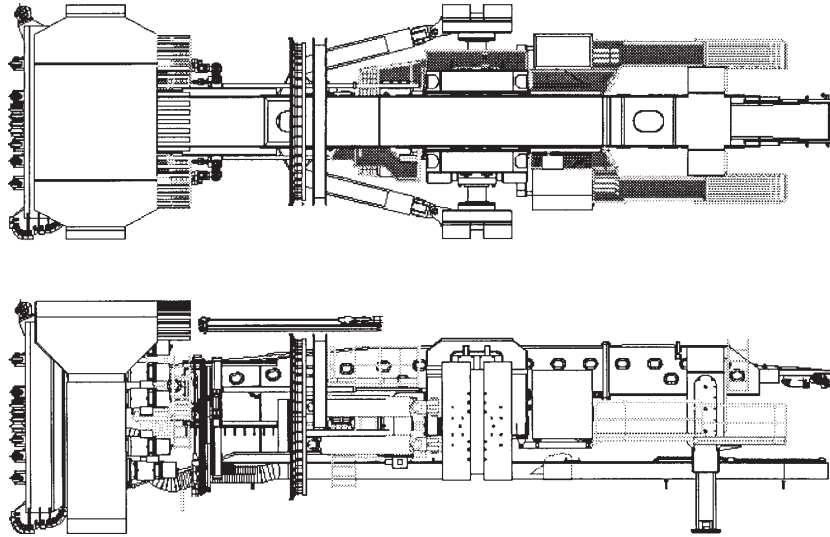

Figure 2. Plan and Side View of HP TBM 235-282

similar in design to the bearings used on the nine Robbins HP TBMs built to date. The bearing is capable of sustaining the high thrust loads realized under HP operation.

The three element bearing design is very well suited for sustaining the eccentric loads which can occur during steering of the machine or in blocky face conditions.

Each drive train, as shown in Figure 4, consists of a single speed electric motor, gear reducer, and a hydraulic actuated friction clutch mounted to the rear of the train for easy access. The drive trains all mesh on a common main drive gear.

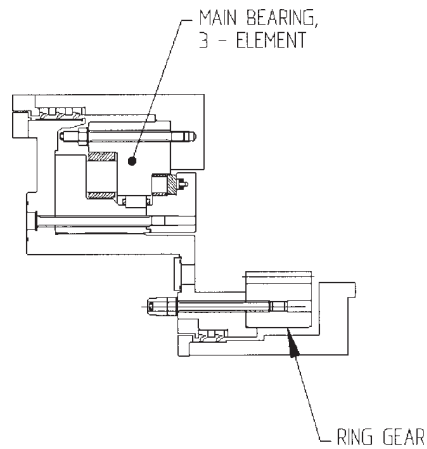

Figure 3. Main Bearing, Ring Gear, Seals

HIGH PERFORMANCE TUNNEL BORING MACHINE FOR WATER TUNNEL 205

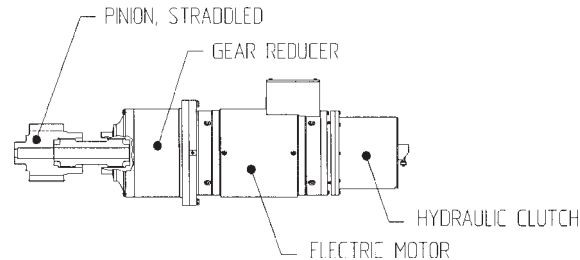

Figure 4. Drive Train

This provides a rugged system, capable of delivering very high breakout torque as well as sustaining a high running torque.

The anticipated rock conditions are very well suited to this system, since the tunnel is expected to be in fairly uniform and competent ground.

Should the cutterhead get stuck in blocky ground conditions, the high breakout torque can be very useful. By momentarily applying approximately two times the running torque, the head can in many cases be broken free. This is done by bringing the motors up to full speed and then taking them off line. The clutches are engaged and the rotational inertia of the motors is transferred to the cutterhead.

The machine currently has 10 drive trains, each rated at 315 kW (422 hp). Total installed cutterhead power is therefore 3150 kW (4220 hp).

The speed of the cutterhead is 8.3 rpm. This provides a cutterhead peripheral velocity of 184 m/min (604 fpm).

Gripper and Thrust System

The thrust system consists of four propel cylinders that provide the required cutterhead thrust at a pressure which is lower than the hydraulic system design pressure. This further increases the safety factor already designed into the hydraulic system. Hence, the system wear factors are decreased.

The gripper system, as shown in Figure 5, consists of a large bore, double rod gripper cylinder and two gripper shoe assemblies. The gripper cylinder is capable of providing a gripping force which is many times greater than the thrust force of the machine. This ensures a rigid anchoring system during forward propulsion of the TBM with virtually no slippage of the gripper shoes on the tunnel wall. The contact area of gripper shoes are large enough to maintain the ground pressure at low enough levels. The gripper shoes are slotted to accommodate the systematic rock bolt pattern along the length of the tunnel.

Auxiliary Systems

The TBM is equipped with a hydraulic service hoist assembly with a capacity of 4 tons.

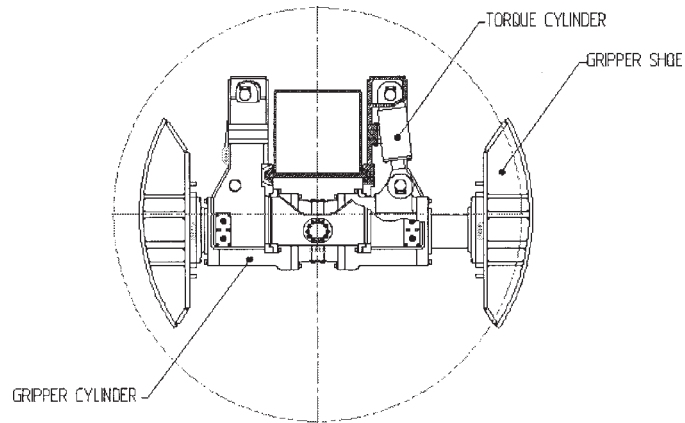

Figure 5. Gripper Cylinder and Gripper Shoes

The hoist is used for transport of cutters and supplies from the front end of the back-up system to the area behind the cutterhead support.

Ground Support System

The TBM is also equipped with roof and probe drilling systems. The roof bolting system, as shown in Figure 6, consists of two Atlas Copco COP1238 rock drills mounted to the TBM in such a way that rock bolts can be installed in the upper half of the tunnel cross section as the TBM moves forward.

The probe drilling system, as shown in Figure 7, consists of an Atlas Copco COP1238

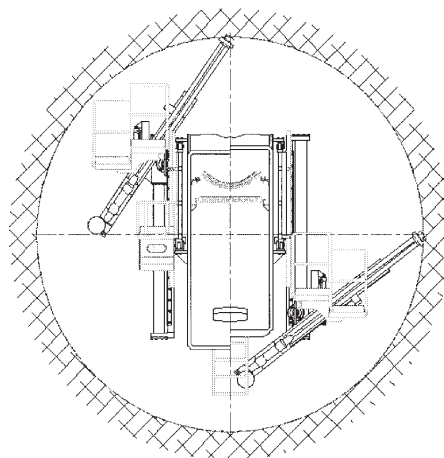

Figure 6. Roof Drills

HIGH PERFORMANCE TUNNEL BORING MACHINE FOR WATER TUNNEL 207

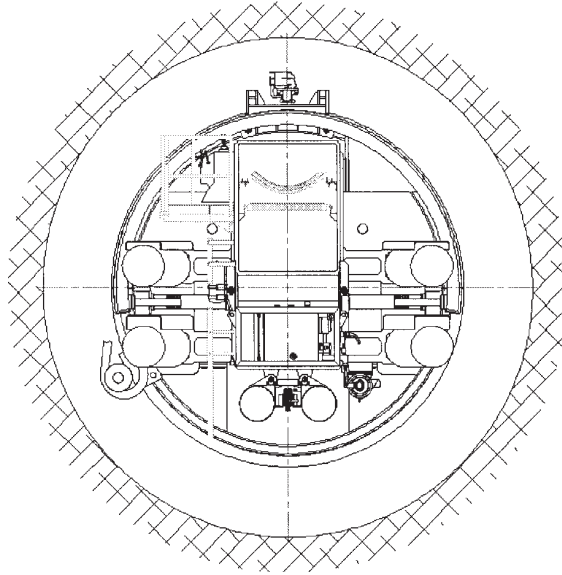

Figure 7. Probe Drill Circular Track Arrangement

rock drill, mounted to the main beam via a circular track, that is used to probe ahead of the TBM either through the face or above the cutterhead at a slight angle to detect any water or differing rock conditions.

Back-up System

Behind the TBM is the 55 m (180 ft) back-up system manufactured by Boretac Inc. This system, which is continuously towed by the TBM, consists of a bridge between the rear section of the TBM, a transfer conveyor, 6 rolling gantry cars with upper and lower decks, and one ramp section.

The lower deck of gantry car number six contains a single rail track, coupled to a turn out assembly on car five, thus allowing a double track setup on cars two through four. Supplies such as rails, continuous conveyor components, fan lines, etc. can be stored on one side, leaving the other side free for trains. Attached to deck one is the continuous conveyor advancing tail piece

The upper deck of car two carries the TBM transformer/electrical cabinet assemblies. The upper deck of the remaining cars contain an air scrubber and fans, fresh water tank and pumps, advancing tail piece power pack, emergency generator for dewatering pumps, high voltage cable storage, and ventilation fan line erector.

A hopper on the back-up system transfers the muck from the bridge conveyor, located in between the TBM and the back-up system, to the continuous conveyor that transport the muck out of the tunnel.

TBM OPERATION

TBM Manufacture

The TBM was designed and manufactured in approximately 10 months. Throughout the designing and manufacturing of the machine several meetings were held between Atlas Copco Robbins Inc., Grow-Perini-Skanska, and outside consultants to review the progress of the operation in order to produce the best possible product. Manufacturing of major structural components and assembly of the TBM was subcontracted to Markham and Company, Ltd. of Chesterfield, England. Under the terms of the contract, Markham built and assembled the TBM according to the drawings and specifications that were provided by Atlas Copco Robbins Inc., and under the supervision of Atlas Copco Robbins and Grow-Perini-Skanska personnel. The machine was shipped to Port Elizabeth, NJ, in June of 1996 and transported to the job site by both truck and barge.

Site Assembly

All components of the TBM were lowered to the bottom of a 204 m (670 ft) deep, and 9.1 m (30 ft) diameter shaft. Prior to the TBM assembly, an erection chamber was drilled and blasted at the base of the shaft. A 107 m (350 ft) long starter tunnel and a 55 m (180 ft) long tail tunnel were also constructed. A mud slab was poured in the entire invert with two each C15x40 channels embedded in the slab and centered and spaced at 2.3 m (7 ft 7 in). Gripper walls were poured in the last 20 m (66 ft) of the starter tunnel from the invert to 6 m (19 ft 6 in) above the mud slab. Walls were built to provide support for the gripper shoes during the initial tunnel boring.

The TBM cutterhead was manufactured in 3 pieces which were welded together at the job site. A framed tent was erected over the cutterhead to protect the welding operation from the elements and a local welding company was contracted to perform the welding which required 63 m (206 ft) of fillet weld. A detailed sequence of assembly of major TBM components was developed prior to lowering of the major components down the shaft for the final assembly. The five major heavy components of the TBM are, main beam at 85.2 tons (188,000 lb), cutterhead support and main bearing and seals assembly at 110 tons (242,000 lb), gripper carrier at 67 tons (148,000 lb), rear support at 34 tons (75,000 lb), and cutterhead at 79 tons (175,000 lb). These components were lowered by using an American 480B winch mounted on a specially designed frame. Two Manitowac M250 cranes, with rated capacity of 300 tons each and with 46 m (150 ft) long booms, were used to pick the winch and frame assembly, hold them over the load so that the load could be connected to the winch, and pick the entire winch, frame, and load assembly, and set the frame over the shaft. After placement of the frame over the shaft, the winch was used to lower the load to the bottom of the shaft.

Once at the bottom of the shaft, the major components were set on dollies with Hillman rollers attached to the bottom of each dolly. The dollies rode in the channels which were embedded in the mud slab. Air tuggers were installed in the starter and tail tunnels and were used to move the TBM components in either direction to connect the pieces.

Once the five major heavy components were lowered and connected to each other, one Manitowac M250 with three parts of line, with total capacity of 41 tons (90,000 lb), was

HIGH PERFORMANCE TUNNEL BORING MACHINE FOR WATER TUNNEL 209

used to lower and assemble the remaining components.

Upon delivery of the back-up system components to the job site, they were set up on a 55 m (180 ft) long section of track and as many back-up components as possible were installed. Deck one was lowered first, by the Manitowac M250, and was set on the track at the bottom of the shaft and pulled into the tail tunnel. The bridge between the TBM and deck one was lowered and attached to the TBM rear section and deck one. The continuous conveyor advancing tail piece and the bridge conveyor were installed next. Decks two through six were installed in the same manner and the back-up system components were installed on the decks while cars were at the bottom of the shaft. After completion of assembly of each car, it was advanced toward the heading by the air tuggers in the starter tunnel, and connected to the rest of the system.

Muck Transport System

In the Queens tunnel, a continuous conveyor system, supplied by Long Airdox and with a belt width of 610 mm (24 in) is used to transport the muck from the TBM back to the shaft 19B at a rate of 550 tons (1,213,000 lb) per hour with a belt speed of 4.5 m/s (880 fpm). The tunneling crew will install conveyor mounting brackets at regular intervals on the left hand side wall of the tunnel, in the area between the TBM and the back-up system. The advancing tail piece of the conveyor which is installed on the first deck of the back-up, is continuously pulled forward by the TBM. As the tunnel is driven, the conveyor is extended with 450 m (1500 ft) long belt sections, allowing the TBM to advance 225 m (750 ft) at a time. Each new section is quickly spliced in at the combined storage/take up unit located in the starter tunnel.

At the bottom of the shaft, the continuous conveyor deposits the muck, via a hopper, onto a Vertical Pocket Lift Conveyor. This conveyor is designed and supplied by the Lakeshore Mining Company. The steel cord belt, supplied by Trellex of Germany, is capable of elevating the muck to the top of the shaft at a rate of 570 tons (1,257,000 lb) per hour with a belt speed of 2.5 m/s (492 fpm).

The muck coming out of the shaft is dumped onto a 125 m (410 ft) long transfer conveyor and is deposited 20 m (66 ft) off the ground in a 2,250 m³ (2943 yd³) muck pile alongside the Long Island Railroad (LIR) siding located on the site.

TBM Performance

At the time of writing of this paper the TBM had just started the boring operation and no meaningful performance data were available.

SUMMARY

The Queens Water Tunnel, No. 3, Stage 2, is a phase in the largest and most costly construction project in the history of New York City. This paper illustrates the planning and the multitude of equipment that are involved in this enormous tunneling project.